

M12HSFSM-0 HIGHSPEED DRAIN CLEANER XXX

4933498377 - M12HSFSM-0 - 4000505320

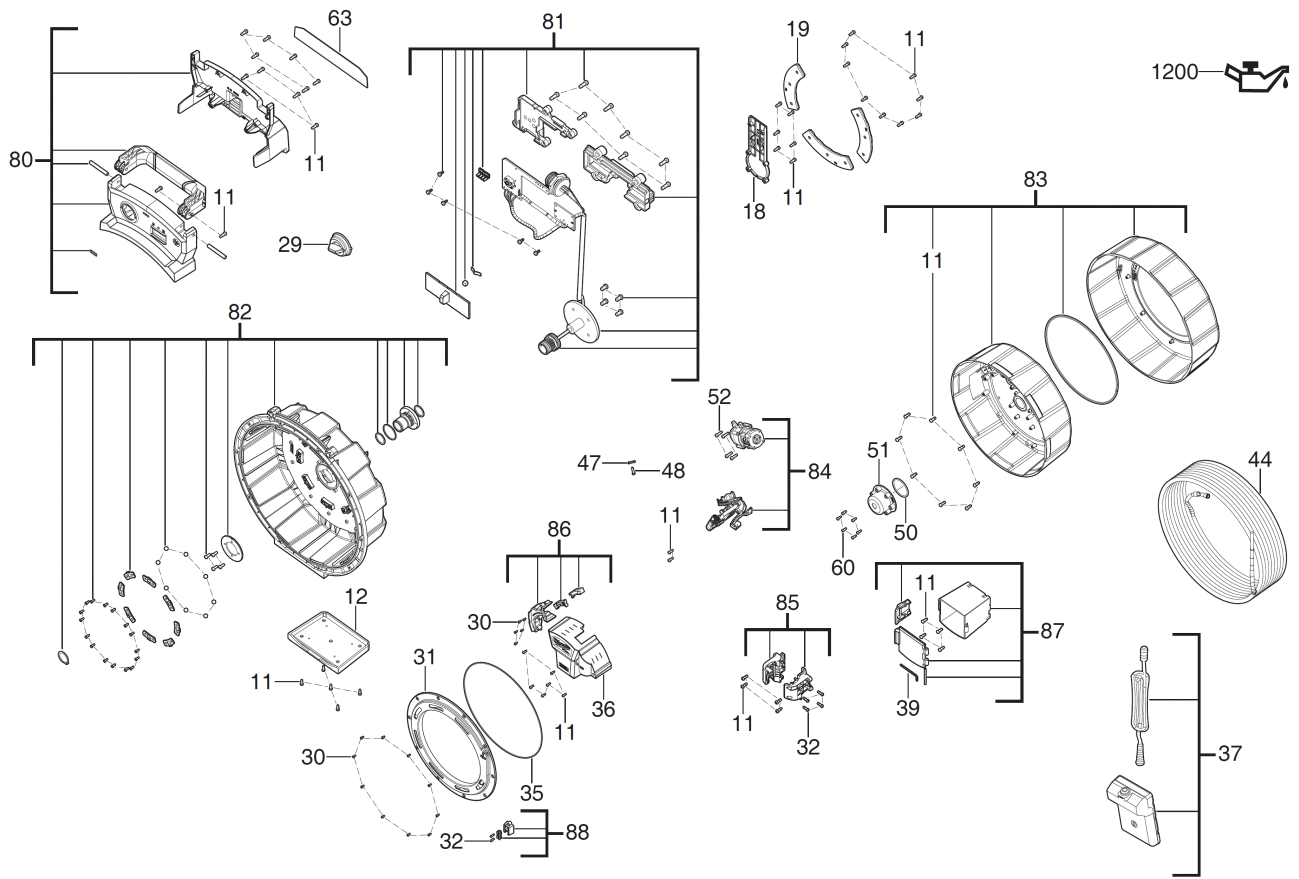



Position	Quantity	Description	Part number	EAN
0011 1	56	SCREW	4931454800	4058546014179
0012 2	1	PAD	4931507598	4058546601096
0018 3	1	BRACKET	4931507599	4058546601102
0019 4	1	PAD	4931507600	4058546601119
0029 5	1	SPEED CONTROL	4931507601	4058546601126
0030 6	15	SCREW	4931506763	4058546560775
0031 7	1	COVER	4931507602	4058546601133
0032 8	6	SCREW	4931496890	4058546540272
0035 9	1	O-RING	4931507603	4058546601140
0036 10	1	COVER	4931507604	4058546601157
0037 11	1	FOOT PEDAL	4931465496	4058546235963
0039 12	1	HEX WRENCH	4931506589	4058546559038
0047 13	1	PIN	4931507605	4058546601164
0048 14	1	PIN	4931507606	4058546601171
0050 15	1	HANDLE	4931507607	4058546601188
0051 16	1	O-RING	4931507608	4058546601195
0052 17	4	SCREW	4931465543	4058546236434
0060 18	6	SCREW	4931506029	4058546553432
0063 19	1	RATING PLATE	4931507609	4058546601201
0080 20	1	HANDLE	4931507610	4058546601218
0081 21	1	SWITCH BOARD	4931507611	4058546601225
0082 22	1	HOUSING COVER	4931507612	4058546601232
0083 23	1	HOUSING	4931507613	4058546601249
0084 24	1	GEAR CASE	4931507614	4058546601256
0085 25	1	BATTERY BOX	4931507615	4058546601263
0086 26	1	COVER	4931507616	4058546601270
0087 27	1	HOUSING COVER	4931507617	4058546601287
0088 28	1	CLIP	4931507618	4058546601294
1200 29	1	ACEITE PARA M18HSFSM 500ML	4932480905	4058546411909