

M18FCSSM-121 FLEXIBLE SHAFT MACHINE IN2

4933499308 - M18FCSSM-121 - 4000481052

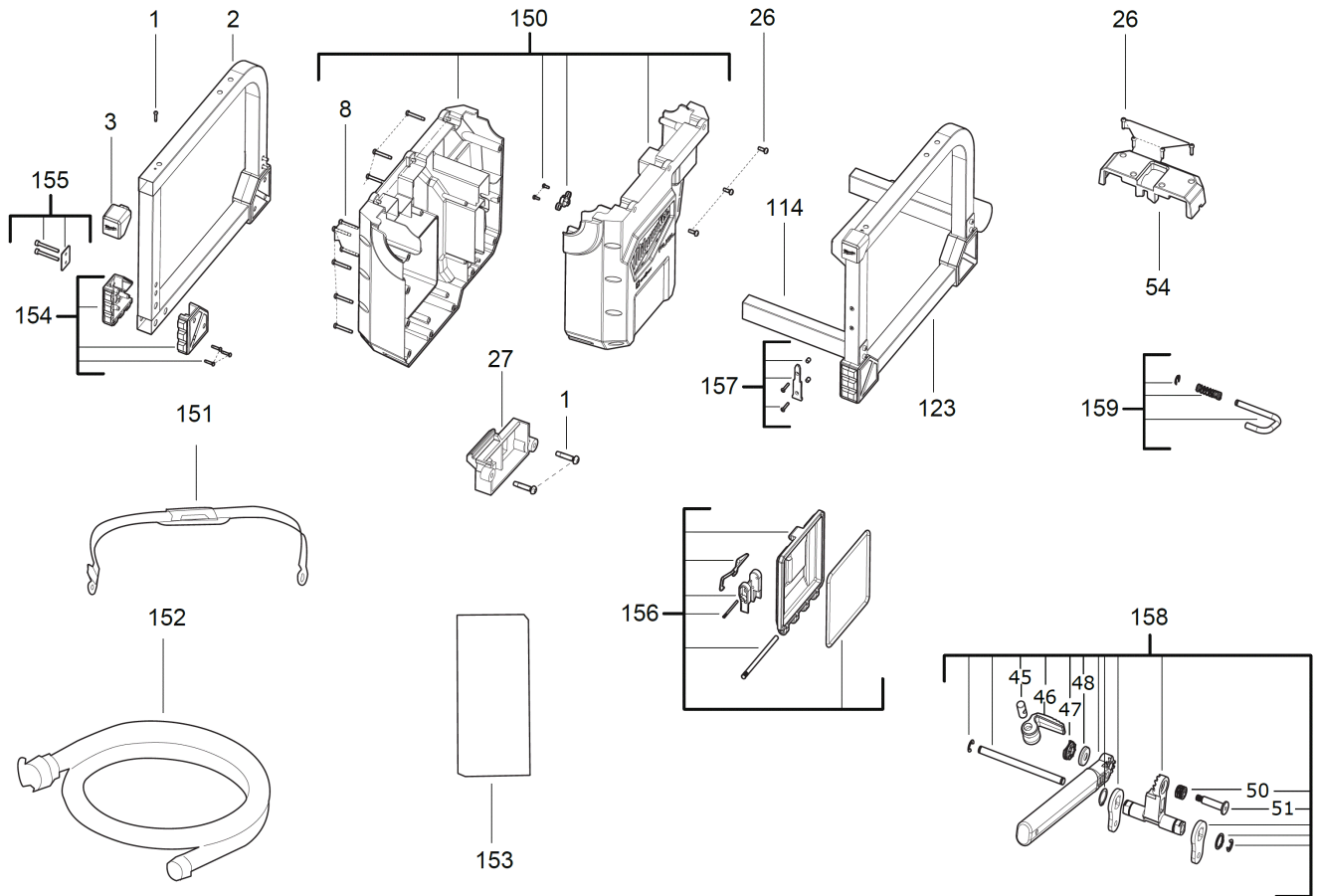

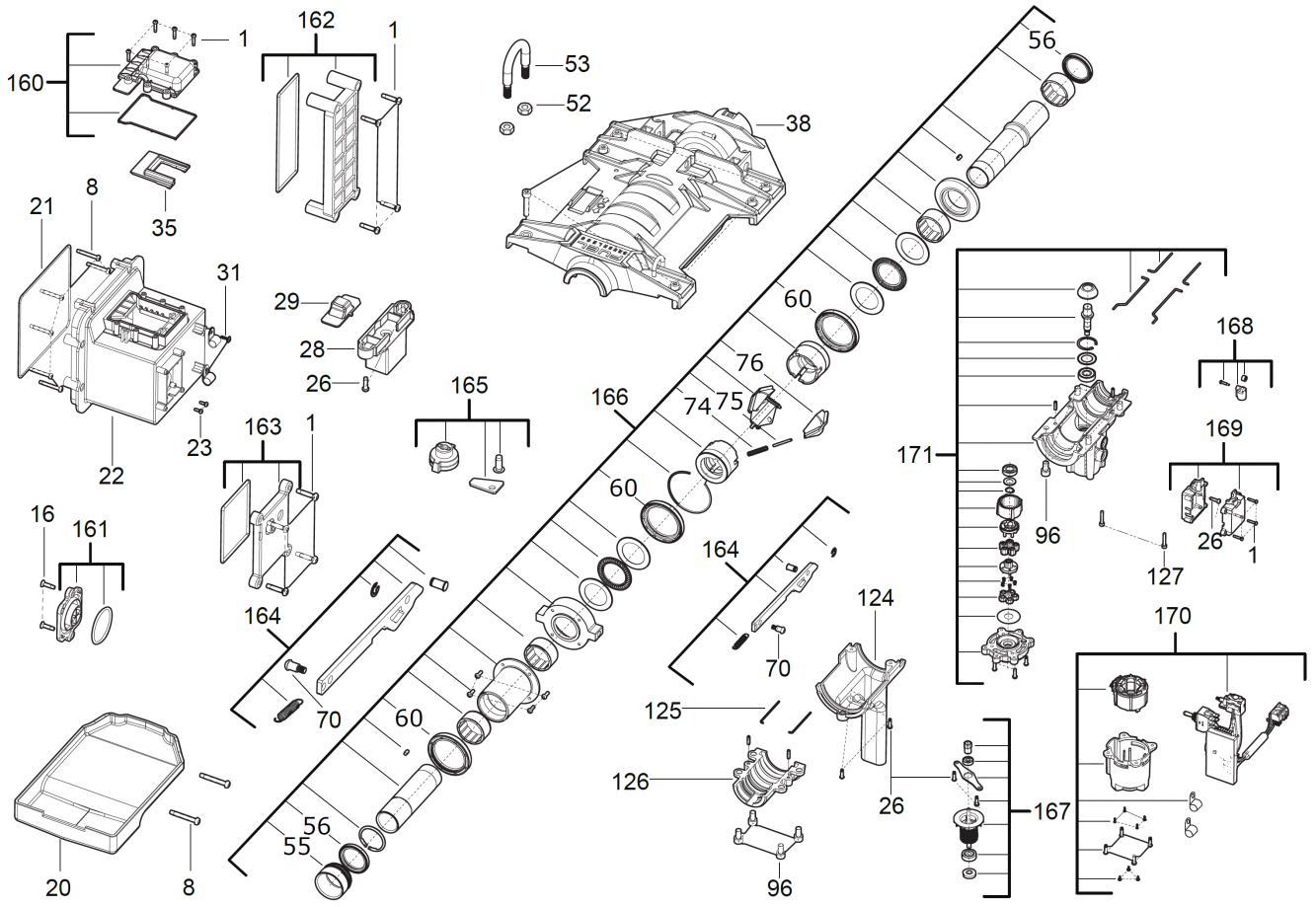

Position	Quantity	Description	Part number	EAN
0001 1	35	SCREW	660570005	4002395827329
0002 2	1	FRAME	4931479019	4058546365875
0003 3	2	CAP	4931479020	4058546365882
0008 4	20	SCREW	4931435023	4002395857302
0016 5	2	SCREW	4931479021	4058546365899
0020 6	1	COVER	4931479022	4058546365905
0021 7	1	GASKET	4931479023	4058546365912
0022 8	1	HOUSING	4931479024	4058546365929
0023 9	4	SCREW	4931431788	4002395895717
0026 10	27	SCREW	4931435150	4002395859948
0027 11	1	HOOK	4931479025	4058546365936
0028 12	1	SWITCH MOUNTING	4931479026	4058546365943
0029 13	1	SLIDING SWITCH	4931465477	4058546235772
0031 14	2	SCREW	660960001	4002395823802
0035 15	1	SUPPORT	4931479027	4058546365950
0038 16	1	HOUSING	4931479028	4058546365967
0045 17	1	BUSH	4931496620	4058546537579
0046 18	1	TENSION LEVER	4931496462	4058546535995
0047 19	1	SPACER	4931496463	4058546536008
0048 20	1	WASHER	4931496464	4058546536015
0050 21	1	PRESSURE SPRING	4931496465	4058546536022
0051 22	1	SHAFT	4931496466	4058546536039
0052 23	4	NUT	4931479029	4058546365974
0053 24	2	HOLDING BRACKET	4931479030	4058546365981
0054 25	1	COVER	4931479031	4058546365998
0055 26	1	GUIDE	4931511438	4058546652944
0056 27	2	SEAL	4931511439	4058546652951
0060 28	3	SEAL	4931511440	4058546652968
0070 29	2	SCREW	4931479032	4058546366001
0074 30	3	SPRING	4931480402	4058546424176
0075 31	3	PIN	4931480403	4058546424183
0076 32	3	COLLET	4931480404	4058546424190
0096 33	8	SCREW	Item discontinued(4931435697)	
0114 34	2	LATCH BAR	4931479033	4058546366018
0123 35	1	FRAME	4931479034	4058546366025
0124 36	1	DEFLECTOR	4931479035	4058546366032
0125 37	2	GASKET	4931479036	4058546366049
0126 38	1	HOUSING	4931479037	4058546366056
0127 39	2	SCREW	4931461267	4058546034399
0150 40	1	HOUSING	4931479038	4058546366063
0151 41	1	STRAP	4931479039	4058546366070
0153 42	1	RATING PLATE	4931479040	4058546366087
0154 43	4	FOOT	4931479041	4058546366094
0155 44	4	WASHER	4931479042	4058546366100
0156 45	1	COVER	4931479043	4058546366117
0157 46	1	HOLDER	4931479044	4058546366124
0158 47	1	LEVER	4931479045	4058546366131
0159 48	1	HOOK	4931479046	4058546366148
0160 49	1	TERMINAL STRIP	4931479047	4058546366155
0161 50	1	COVER	4931479048	4058546366162

Position	Quantity	Description	Part number	EAN
0162 51	1	COVER	4931479049	4058546366179
0163 52	1	COVER	4931479050	4058546366186
0164 53	2	ROD	4931479051	4058546366193
0165 54	1	RETAINER	4931479052	4058546366209
0166 55	1	DRIVE	4931479053	4058546366216
0167 56	1	ROTOR	4931479054	4058546366223
0168 57	1	TRIGGER	4931479055	4058546366230
0169 58	1	COVER	4931479056	4058546366247
0170 59	1	ELECTRONIC	4931479057	4058546366254
0171 60	1	GEAR BOX	4931479058	4058546366261
0152 61	1	Medium Guide Hose for FCSSM	4932478409	4058546346003