

# AG22-180 WINKELSCHLEIFER IN2

4933431830 - AG22-180<sup>®</sup><sup>®</sup><sup>®</sup>DMS -  
4000431831

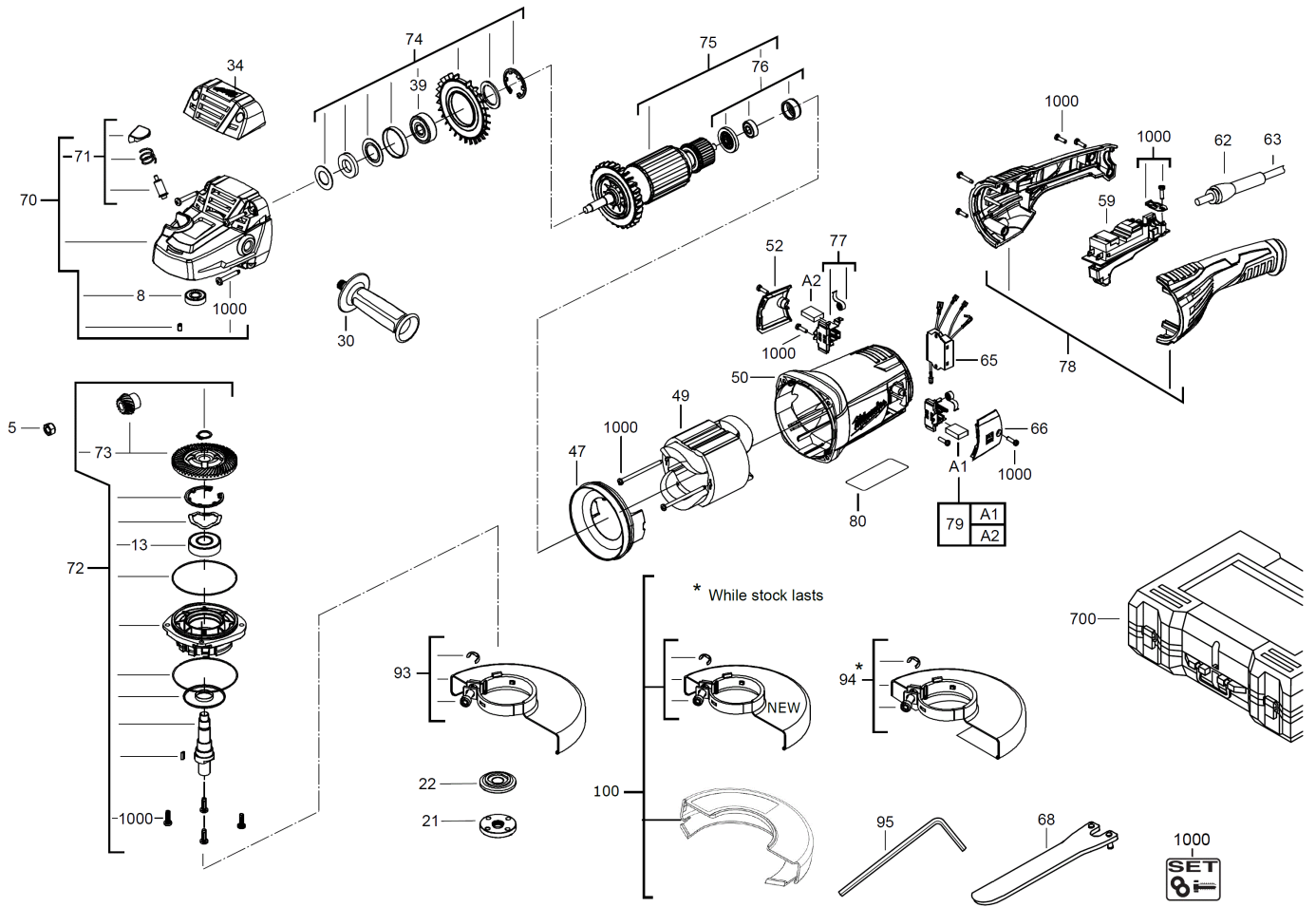



Position	Quantity	Description	Part number	EAN
0005 1	1	MUTTER	4931441045	4002395862603
0008 2	1	LAGER	4931441046	4002395862610
0013 3	1	LAGER	4931441047	4002395862627
0021 4	1	FLANSCHMUTTER	4931441048	4002395862634
0022 5	1	FLANSCH	4931441049	4002395862641
0030 6	1	HANDGRIFF	4931441050	4002395862658
0034 7	1	GETRIEBEKASTEN	4931441052	4002395863365
0039 8	1	LAGER	4931441053	4002395863372
0047 9	1	LUFTFUEHRUNGSRING	4931441054	4002395863389
0049 10	1	FELD F. ELEKTROMOTOR	4931441055	4002395863396
0050 11	1	MOTORGEHAEUSE	4931441057	4002395864010
0052 12	1	BUERSTENABDECKUNG	4931441058	4002395864027
0059 13	1	SCHALTER	4931441061	4002395864041
0062 14	1	KABELSCHUTZSCHLAUCH	4931441064	4002395864072
0063 15	1	ANSCHLUSSLEITUNG	4931441066	4002395864096
0065 16	1	Für diese Version nicht verfügbar	1000000003	
0066 17	1	BUERSTENABDECKUNG	4931441074	4002395861347
0068 18	1	SCHLUESSEL	4931441075	4002395861354
0070 19	1	Getriebekasten	4931441090	4002395863419
0071 20	1	VERRIEGEL.-ELEMENT	4931441091	4002395863426
0072 21	1	SPINDEL	4931441092	4002395863433
0073 22	1	GETRIEBE	4931441096	4002395863471
0074 23	1	LAGERSATZ	4931441098	4002395863495
0075 24	1	ANKER F.ELEKTROMOTOR	4931441099	4002395864102
0076 25	1	KUGELLAGER	4931441101	4002395864126
0077 26	1	BUERST.HALTER KOMPL	4931441102	4002395864133
0078 27	1	GEHAEUSE	4931441103	4002395864140
0079 28	1	KOHLEBUERSTEN-SET	4931441104	4002395864157
0080 29	1	LEISTUNGSSCHILD	4931441077	4002395862054
0093 30	1	SCHUTZHAUBE	4931441109	4002395864164
0094 31	1	SCHUTZHAUBE	Item discontinued(4931441111)	
0095 32	1	SCHLUESSEL	4931441089	4002395863402
0100 33	1	SCHUTZHAUBEN-SET	4931510996	4058546636814
0700 34	1	TRANSPORTKOFFER	Item discontinued(4931441113)	
1000 35	1	SCHRAUBENSET	4931441114	4002395861408