

# M18BLSAG125X-402X A.-Winkelschleifer IN2

4933492644 - M18BLSAG125X-402X - 4000497215

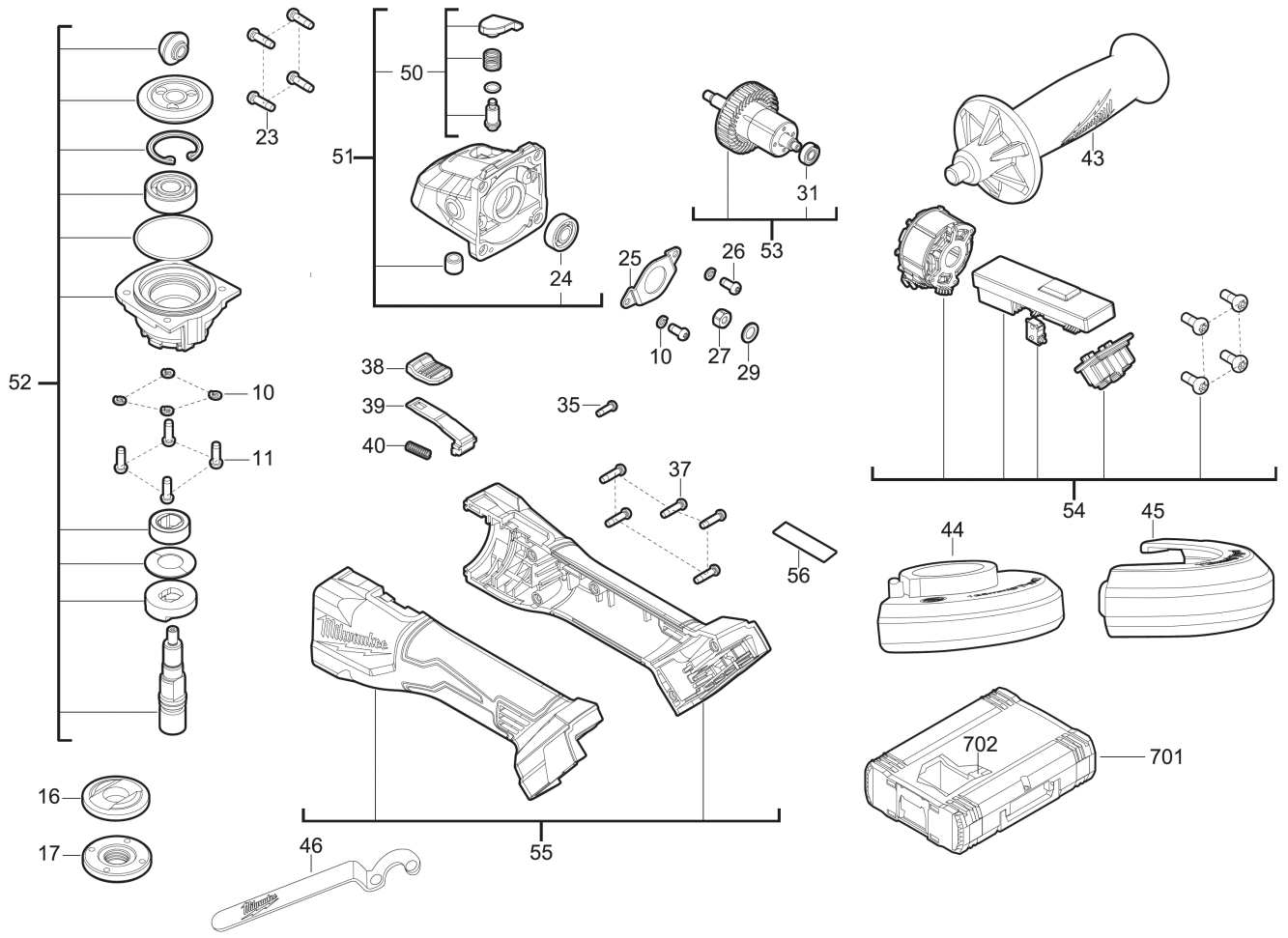



Position	Quantity	Description	Part number	EAN
0010 1	6	SICHERUNGSRING	680866003	4002395823895
0011 2	4	SCHRAUBE	4931435150	4002395859948
0016 3	1	FLANSCH	4931479268	4058546385835
0017 4	1	FLANSCHMUTTER	4931441309	4002395887699
0023 5	4	SCHRAUBE	660024030	4002395826957
0024 6	1	KUGELLAGER	4931448373	4002395250769
0025 7	1	HALTER	4931479269	4058546385842
0026 8	2	SCHRAUBE	660165015	4002395849826
0027 9	1	MUTTER	671686001	4002395824526
0029 10	1	SCHEIBE	4931479270	4058546385859
0031 11	1	KUGELLAGER	4931495379	4058546490478
0035 12	1	SCHRAUBE	4931436686	4002395258260
0037 13	5	SCHRAUBE	660031017	4002395825189
0038 14	1	SCHIEBER	4931479272	4058546385873
0039 15	1	FEDER	4931479273	4058546385880
0040 16	1	SCHIEBER	4931495390	4058546490584
0043 17	1	ZUSATZHANDGRIFF	4931435001	4002395855902
0044 18	1	SCHUTZ	4931479287	4058546386023
0045 19	1	TRENNSCHUTZHAUBE	4931479288	4058546386030
0046 20	1	SCHLUESSEL	632145002	4002395823727
0050 21	1	ARRETIERUNG	4931495381	4058546490492
0051 22	1	GETRIEBEKASTEN	4931495382	4058546490508
0052 23	1	SPINDEL SATZ	4931495383	4058546490515
0053 24	1	ANKER F.ELEKTROMOTOR	4931495384	4058546490522
0054 25	1	ELEKTRONIK	4931495385	4058546490539
0055 26	1	GEHAEUSE	4931495386	4058546490546
0056 27	1	LEISTUNGSSCHILD	4931495391	4058546490591
0702 28	1	EINLEGETEIL	4931495388	4058546490560